

---

# FS-978

**Serial**

**User's Manual  
Version 1.1  
2004/11/24**

## **Copyright**

Copyright® 2003 -2004. All rights reserved. This document is copyrighted and all rights are reserved. The information in this document is subject to change without prior notice to make improvements to the products.

This document contains proprietary information and protected by copyright. No part of this document may be reproduced, copied, or translated in any form or any means without prior written permission of the manufacturer.

All trademarks and/or registered trademarks contains in this document are property of their respective owners.

## **Disclaimer**

Taiwan Commate Computer Inc. shall not be liable for any incidental or consequential damages resulting from the performance or use of this product. Taiwan Commate Computer Inc. does not issue a warranty of any kind, express or implied, including without limitation implied warranties of merchantability or fitness for a particular purpose.

The company has the right to revise the manual or include changes in the specifications of the product described within it at any time without notice and without obligation to notify any person of such revision or changes.

## **Trademark**

All trademarks are the property of their respective holders.

Any question please visit our website at <http://www.commell.com.tw>.

---

# Packing List

---

## Hardware

FS-978 Single Board Computer ..... X 1

## Cable Kit

34-pin FDD Cable ..... X 1  
1 x COM / 1 x LPT Port DB9 / DB25 Cable (VL/VLS only) X 1  
2 x COM Port DB9 Cable (VL2/VL2S only) ..... X 1  
1 x LPT Port DB25 Cable (VL2/VL2S only)..... X 1  
Dual-USB Port Cable with Bracket..... X 2  
PS/2 Keyboard and Mouse Cable ..... X 1  
Serial ATA Cable ..... X 1  
40-pin UltraATA/100 IDE Cable ..... X 2  
Audio Cable ..... X 1  
3-pin to 4-pin ATX cable..... X 1

## CD Content

User Manual  
Driver

---

## Table of Content

<b>Chapter 1. Introduction .....</b>	<b>5</b>
1.1 Product Overview .....	5
1.2 Specification .....	6
1.3 Component Placement .....	11
1.4 Block Diagram .....	12
<b>Chapter 2. Hardware Setup.....</b>	<b>13</b>
2.1 Connector Location .....	13
2.2 CPU and DRAM Setting .....	16
2.3 CMOS Setting .....	16
2.4 Watchdog Timer Setting .....	17
2.5 Embedded Solid State Disk .....	18
2.6 Serial ATA Setup Information .....	19
2.6 Power and Fan Connector.....	23
2.7 VGA Interface .....	25
2.8 Ethernet Interface.....	26
2.9 Audio Interface .....	27
2.10 Switch and Indicator .....	28
<b>Chapter 3. BIOS Setup .....</b>	<b>29</b>
<b>Chapter 4. Driver Installation .....</b>	<b>31</b>

---

<b>Appendix. A</b>	<b>I/O Port Pin Assignment</b> .....	<b>33</b>
A.1	IDE Port .....	33
A.2	Floppy Port.....	34
A.3	Parallel Port .....	35
A.4	Serial Port .....	36
A.5	USB Port .....	37
A.6	IrDA Port .....	37
A.7	VGA Port .....	38
A.8	LAN Port .....	38
A.9	AT Keyboard Port.....	39
A.10	PS/2 Keyboard and Mouse Port.....	39
<b>Appendix B.</b>	<b>Flash the BIOS</b> .....	<b>41</b>
B.1	BIOS Auto Flash Tool .....	41
B.2	Flash Method .....	41
<b>Appendix C.</b>	<b>System Resource</b> .....	<b>43</b>
C.1	I/O Port Address Map.....	43
C.2	Memory Address Map .....	45
C.3	IRQ and DMA Resource.....	46
<b>Contact Information</b>	.....	<b>48</b>

---

# Chapter 1. Introduction

## 1.1 Product Overview

The **FS-978** SBC (Single Board Computer) is an all-in-one industrial full-size PICMG (PCI/ISA)-bus CPU card based on Intel Socket 478 Pentium 4 architecture. With Intel 865G chipset, Intel 865G GMCH and ICH5, **FS-978** offers the value computing solution including Intel NetBurst micro-architecture, 800/533/400 MHz of FSB, 2 GB DDR SDRAM, Intel Extreme Graphics 2 with Intel Dynamic Video Memory up to 64 MBytes, One Intel PRO/100+ LAN and one PRO/1000+ LAN, Hi-Speed USB 2.0 and Compact Flash Type II interfaces.

Based on the Intel's long term supply chipset in the EIA (Embedded Intel Architecture) division's product roadmap, **FS-978** should be the ideal solution for the industrial applied computing platform with high computing capacity, cost effect and long life cycle. With Intel's latest technology, the **FS-978** should be the leading edge of computing capacity for the advanced industrial computing platform with the features as below.

### Intel Hyper-Threading Technology

The **FS-978** supports Intel Hyper-Threading Technology to offer the better computing capacity for the industrial applied computing application. Based on Intel's latest technology, "the Intel Pentium 4 Processor with Hyper-Threading technology allows software programs to "see" two processors and work more efficiently. Improves performance and system responsiveness in today's multitasking environments by enabling the processor to execute instruction threads in parallel."

### Powerful Computing Capacity

With Intel's latest CPU technology, **FS-978** supports Intel Socket 478 Pentium 4 CPU up to 3.2 GHz at 800 MHz of FSB and low cost Intel Socket 478 Celeron CPU from 2.0 GHz up to 2.4 GHz at 400 MHz of FSB. The **FS-978** also provides two GBytes of DDR266/333/400 of system memory capacity.

**Hi-Speed USB 2.0 Interface:** Intel ICH5 built-in Hi-Speed USB 2.0 controller offers the Hi-Speed USB 2.0 interface with up to 480 Mbps of data transfer bandwidth with the USB bootable setting in the BIOS.

---

## 1.2 Specification

### General Specification

<b>Form Factor</b>	Full-size PICMG-bus CPU Card / Slot PC PICMG version 1.0 (Rev. 2.0), PCI version 2.0 compliant
<b>CPU</b>	Intel Socket 478 Pentium 4 / Celeron CPU at 400/533/800 MHz FSB (100/133/200MHz x 4) Intel 0.13-micron Northwood /Prescott CPU <b>Willamette CPU is not supported</b> <b>Support Intel Hyper-Threading Technology</b>
<b>Memory</b>	Two 184-pin DIMM sockets support up to 2 GBytes Dual Channel DDR266/333/400 SDRAM. (No ECC/register DIMM support)
<b>Chipset</b>	Intel 82865G GMCH and 82801EB ICH5
<b>BIOS</b>	Phoenix-Award 2Mb PnP flash BIOS
<b>Green Function</b>	Power saving mode supported in BIOS with DOZE, STANDBY and SUSPEND modes. ACPI version 1.0 and APM version 1.2 compliant
<b>Watchdog Timer</b>	System reset programmable watchdog timer with 1 to 255 sec./min. of time out value
<b>Real Time Clock</b>	Intel ICH5 built-in RTC with onboard lithium battery
<b>PCI Enhanced IDE</b>	PCI enhanced IDE interface supports dual ports up to 4 ATAPI devices with UltraATA/100 supported
<b>ISA High Drive</b>	ISA 64mA high Drive capacity with TI 245 buffer on both of ISA address and data bus
<b>Serial ATA</b>	Two Serial ATA connectors, data transfer rate up to 150MB/s
<b>Mini AGP Port</b>	Provide the capable of driving an ADD card to support LVDS/TMDS/TV/HDTV devices Provide the capable of driving an Mini AGP card to support AGP 8X/4X graphic card
<b>SCSI</b>	Optional Dual Channel Ultra320 SCSI Adapter, Support up to 15 SCSI Devices each channel

---

## Multi-I/O Port

<b>Chipset</b>	Intel 82801EB ICH5 and Winbond W83627HF-AW LPC super-I/O controller
<b>Serial Port</b>	Two RS-232 serial ports. Both with 16C550 compatible UART and 16 bytes FIFO.
<b>USB 2.0 Port</b>	Four Hi-Speed USB 2.0 ports with Intel ICH5 Support 480 Mbps of data transfer rate
<b>Parallel Port</b>	One bi-direction parallel port with SPP/ECP/EPP mode
<b>Floppy Port</b>	One floppy port supports up to two FDD
<b>IrDA Port</b>	One IrDA compliant Infrared interface supports SIR
<b>K/B &amp; Mouse</b>	PS/2 keyboard and mouse ports, AT keyboard port

## Solid State Disk Interface

<b>Flash Type</b>	IDE Pro and DiskOnModule (DOM) solid state flash disk One Compact Flash Type II interface onboard
<b>Package</b>	40-pin IDE port (DOC IDE Pro, DiskOnModule) 50-pin Compact Flash type II socket
<b>Capacity</b>	1 GB of CF card and 512 MB of DiskOnModule

## VGA Display Interface

<b>Chipset</b>	Intel 865G GMCH built-in Intel Extreme Graphics 2
<b>Video Memory</b>	Intel Dynamic Video Memory with auto detect video memory up to 64 MBytes shared with system memory
<b>Display Type</b>	CRT and LCD monitor
<b>Connector</b>	External DB15 female connector on bracket for CRT Internal 16-pin header for analog VGA display

---

## Ethernet Interface

---

<b>Chipset</b>	Intel PRO/100+ LAN and PRO/1000+ LAN interface Primary LAN (LAN1): Intel 865G with Intel 82547GI CSA Optional secondary LAN (LAN2): Intel ICH5 with 82562ET PHY
<b>Type</b>	82562ET:10Base-T / 100Base-TX Full duplex, IEEE802.3U compliant 82547EI:10Base-T/100Base-TX/1000Base-T Full duplex, IEEE802.3U compliant

---

## Audio Interface

---

<b>Chipset</b>	Intel ICH5 built-in AC97 3D audio controller with codec
<b>Interface</b>	Line-in, line-out, CD-in, Mic-in

---

## ADD-on Card (MA-LVDS)(Optional)

---

<b>Chipset</b>	CHRONTEL 7017A-T
<b>Interface</b>	24-bit Dual Channel LVDS interface TV-out interface

---

## ADD-on Card (MA-ATI)(Optional)

---

<b>Chipset</b>	ATI MOBILITY™ M10
<b>Interface</b>	AGP 8X with 64MB DDR SDRAM onboard 24-bit Dual Channel LVDS interface TV-out interface DVI interface Analog CRT interface

---



---

## Power and Environment

<b>Power Req.</b>	+5V, +12V DC input from PICMG backplane  Onboard 4-pin AT connector for power supply. Additional +12V on 4-pin connector for Pentium 4 PSU
<b>ATX Function</b>	3-pin ATX interface with 5V standby and power-on
<b>Dimension</b>	338 (L) x 122 (H) mm, standard PICMG form factor
<b>Temperature</b>	Operating within 0 ~ 60°C (32 ~ 140°F) Storage within -20 ~ 85°C (-4 ~ 185°F)
<b>EMI</b>	

---

## Ordering Code

<b>FS-978VL</b>	Full-size PICMG Socket 478 Pentium 4 DDR CPU Card with 800/533/400 MHz FSB, Intel Extreme Graphics 2, Intel PRO/1000+ LAN, Audio, Hi-Speed USB 2.0, Compact Flash Socket and ISA 64mA High Drive Capacity
<b>FS-978VLS</b>	Same as <b>FS-978VL</b> but with <b>Ultra 320 SCSI controller</b>
<b>FS-978VL2</b>	Same as <b>FS-978VL</b> but with <b>Dual Intel LAN</b> (one Intel PRO/100+ and One Intel PRO/1000+ LAN)
<b>FS-978VL2S</b>	Same as <b>FS-978VL2</b> but with <b>Ultra 320 SCSI controller</b>

---

**Notes** (This page left blank intentionally)

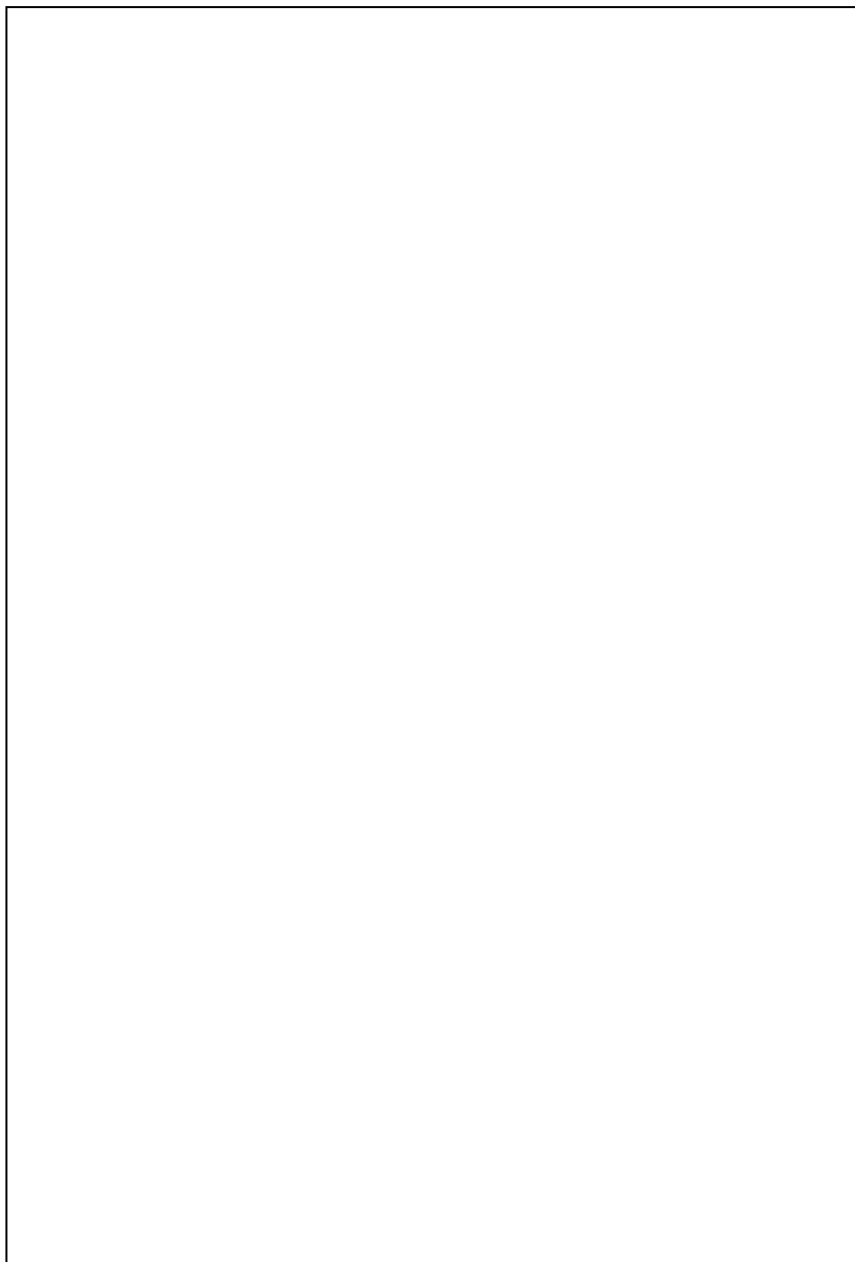
A large, empty rectangular box with a thin black border, occupying most of the page. It is intended for the user to write notes.

## 1.3 Component Placement

System Memory  
2 x 184-pin DIMM Sockets  
2 GB DDR266/333/400 SDRAM

Intel 865G GMCH  
Built-in Intel  
Extreme Graphics 2

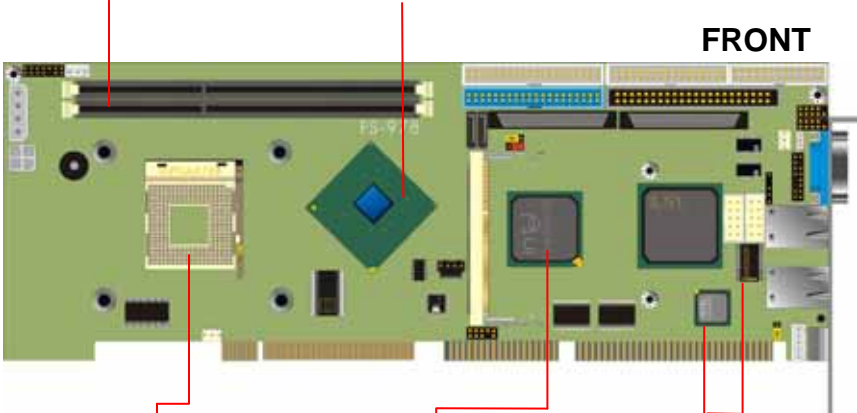

**FRONT**

mPGA478 CPU Socket  
Intel Pentium 4 / Celeron  
800/533/400 MHz FSB

Intel 82801EB ICH5  
Built-in Hi-Speed  
USB 2.0 Interface

Dual Intel LAN  
Intel 82547GI CSA  
and ICH5 with Intel  
82562ET PHY

Winbond 83627HF-AW  
LPC Super-I/O

Compact Flash Type  
II Socket

ITE8888 ISA Bridge

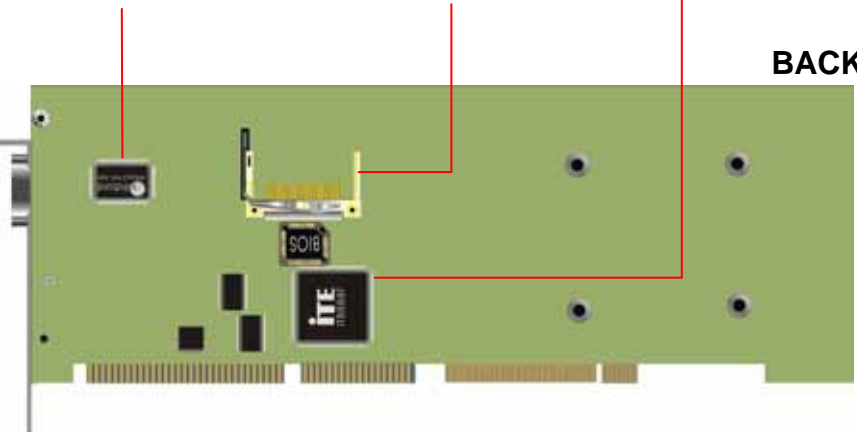

**BACK**

# 1.4 Block Diagram

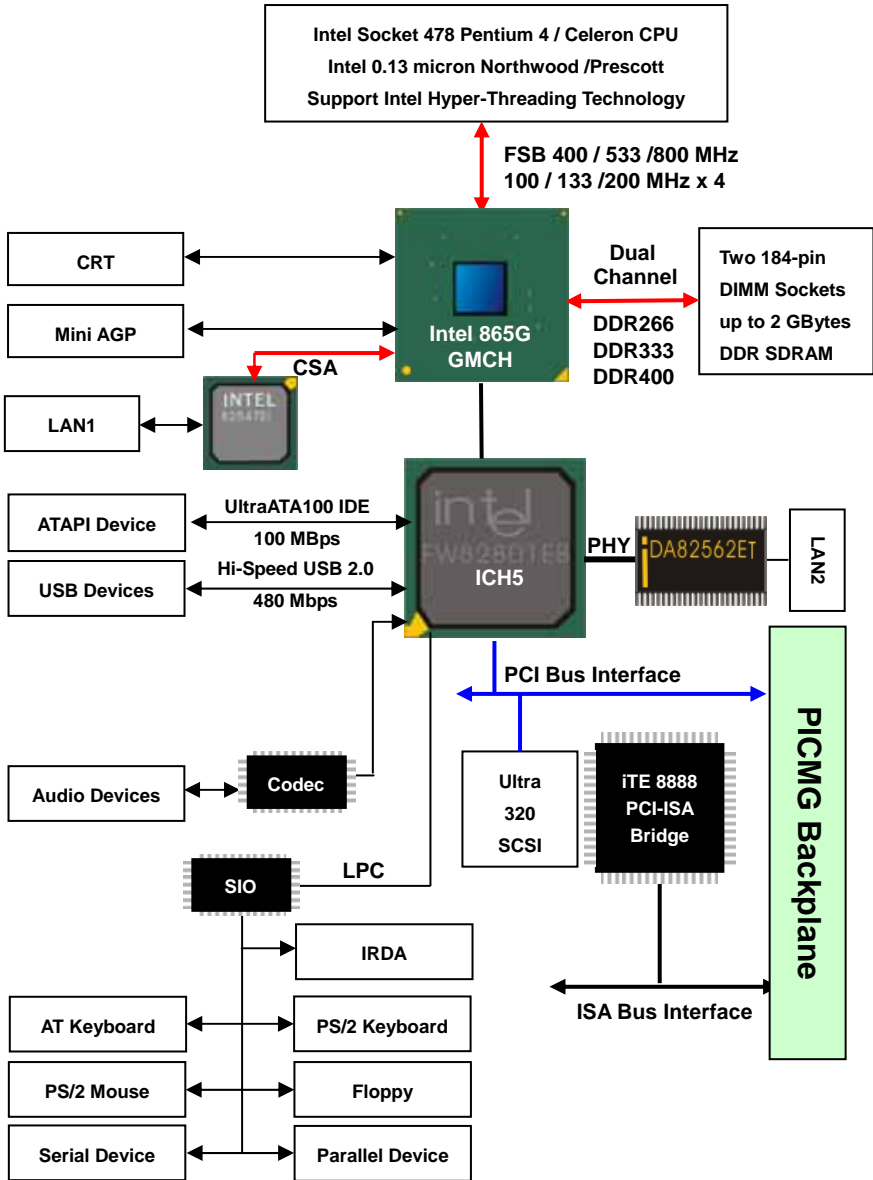

---

## Chapter 2. Hardware Setup

This chapter contains the information for installation of hardware. The install procedure includes jumper settings, CPU and memory installation, fan, I/O and panel connections.

### 2.1 Connector Location

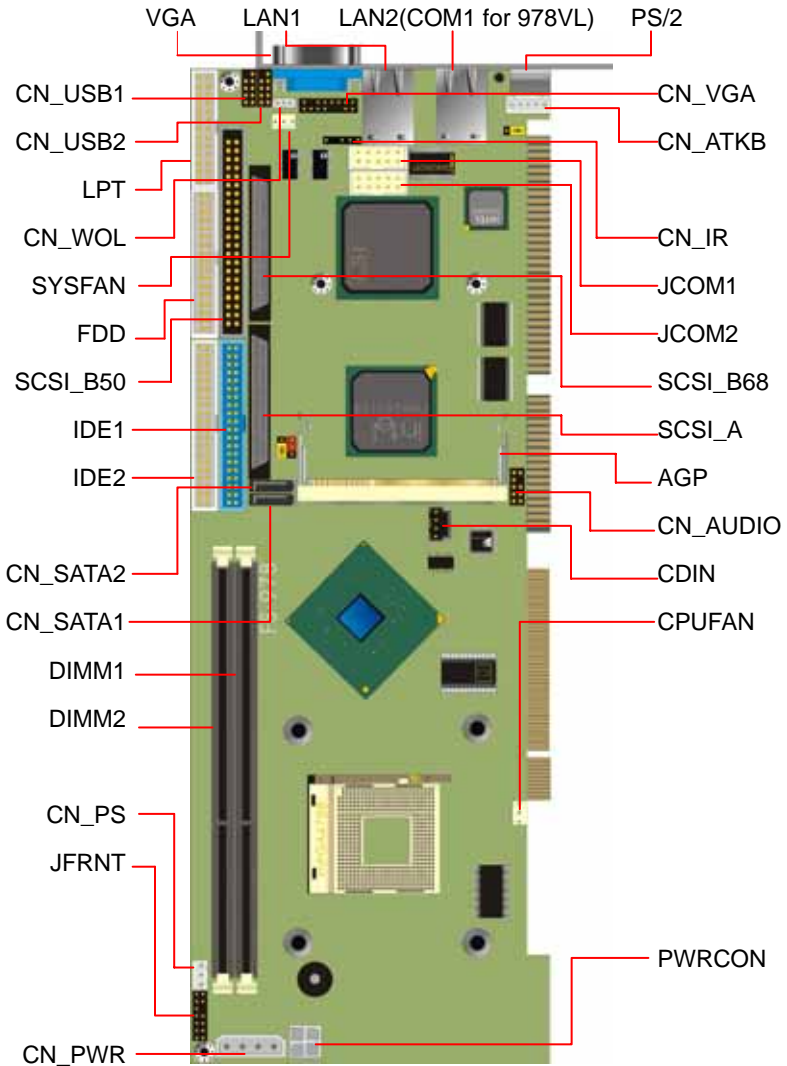

---

## 2.1.1 Jumper Reference

Jumper	Function	Section
JRTC	COMS Operate / Clear Setting	<a href="#">2.3</a>
JWDT	Watchdog Timer NMI / Reset Setting	<a href="#">2.4</a>
JCFSEL	Compact Flash Card Setting	<a href="#">2.5</a>

---

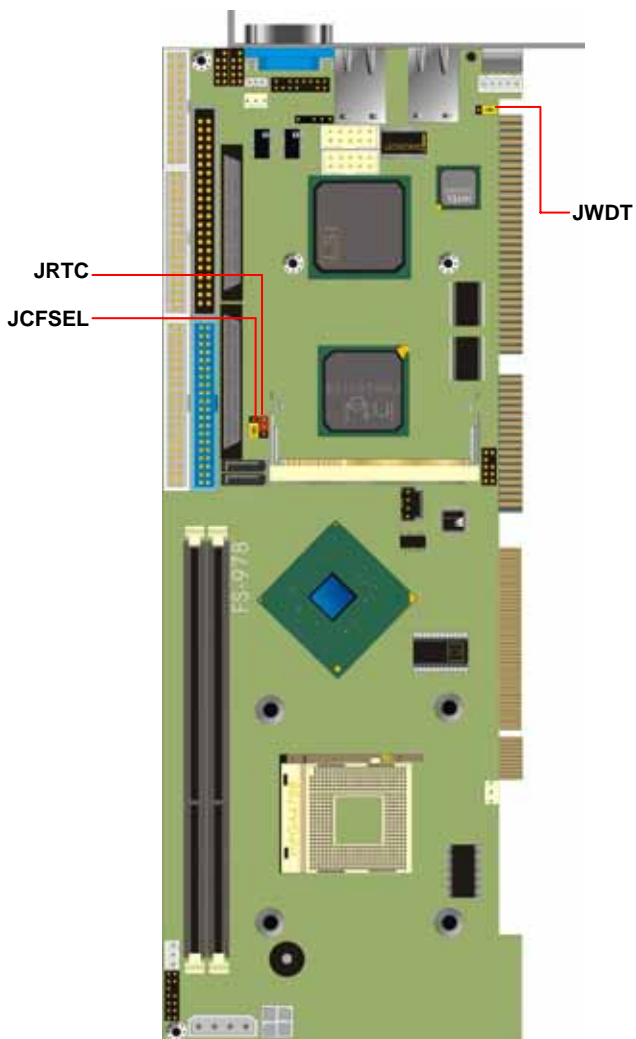

---

## 2.1.2 Connector Reference

### Internal Onboard Connector

Connector	Function	Remark
CPU	MicroPGA478 478 CPU Socket	Standard
DIMM1/2	184-pin DIMM Socket	Standard
IDE1/2	40-pin Primary / Secondary IDE Port	Standard
FDD	34-pin Floppy Port	Standard
LPT	26-pin Parallel Port	Standard
JCOM1/2	10-pin COM1/2 Serial Port	Standard
CN_USB1/2	10-pin 1st / 2nd (3rd / 4th) USB Port	Standard
CN_IR	5-pin SIR IrDA Port	Standard
CN_ATKB	5-pin AT Keyboard Connector	Standard
PWRCON	4-pin Additional +12V Power Connector	Standard
CN_PWR	4-pin +5V & +12V Power Connector	Standard
CN_PS	3-pin ATX Signal Connector	Standard
JFRNT	14-pin Switch and Indicator Connector	Standard
CPUFAN	3-pin +12V CPU Fan Connector	Standard
SYSFAN	3-pin +12V System Fan Connector	Standard
CN_VGA	16-pin Internal VGA Port	Standard
CN_AUDIO	10-pin Audio Port	Standard
CDIN	4-pin CD-in Interface	Standard
CN_WOL	3-pin Wake-On-LAN Interface	Standard
AGP	144-pin Mini-AGP Socket	Standard
CF	50-pin Compact Flash Card Socket	Standard
SCSI_B50	50-pin SCSI connector	VL2S only
SCSI_A	68-pin SCSI connector	VL2S only
SCSI_B68	68-pin SCSI connectors	VL2S only
CN_SATA1/2	Serial ATA connectors	Standard

### External Connector on Bracket

Connector	Function	Remark
VGA	DB15 Female VGA Connector	Standard
LAN1	RJ45 LAN1 Connector	Standard
LAN2	RJ45 LAN2 Connector	VL2 & VL2S only
COM1	DB9 Male COM1 Connector	VL only
PS2	6-pin MiniDIN PS/2 Keyboard & Mouse	Standard

---

## 2.2 CPU and DRAM Setting

The board is based on Intel Socket 478 architecture with Intel 865G chipset, supports Intel Socket 478 Pentium 4 / Celeron CPU at 800/533/400 MHz FSB.

System memory of this board supports up to 2 GBytes DDR266/333/400 SDRAM on two 184-pin DIMM sockets support Dual Channel. Please notices that Intel 865G GMCH **DOESN'T** support ECC and register DIMM.

## 2.3 CMOS Setting

The board's data of CMOS can be setting in BIOS. If the board refuses to boot due to inappropriate CMOS settings, here is how to proceed to clear (reset) the CMOS to its default values.

Jumper: **JRTC**

Type: onboard 3-pin header

JRTC	Mode
1-2	Clear CMOS
2-3	Normal Operation

Default setting

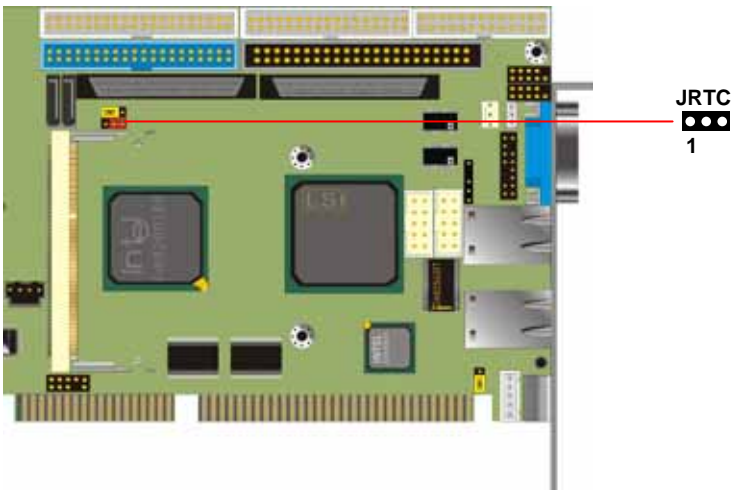



---

## 2.4 Watchdog Timer Setting

The watchdog timer makes the systems auto-reset while it stop to work for a period. The onboard watchdog timer can be setup as system reset or active NMI mode by jumper JWDT.

Jumper: **JWDT**

Type: onboard 3-pin header

<b>JWDT</b>	<b>Watchdog Timer</b>
1-2	Active NMI
2-3	Reset

Default setting

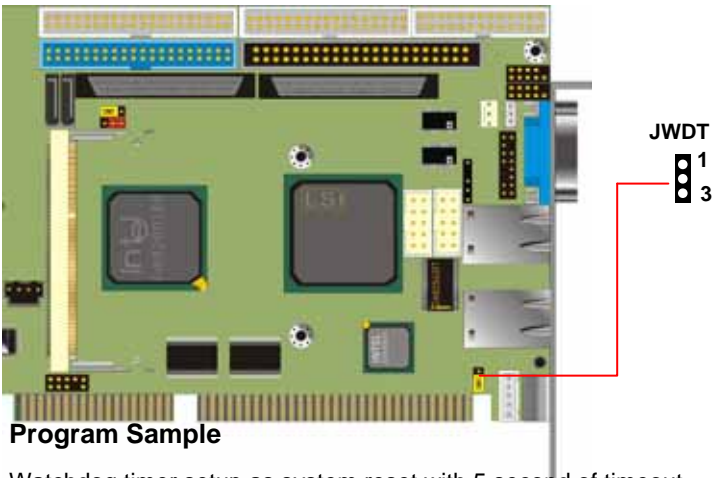

### Program Sample

Watchdog timer setup as system reset with 5 second of timeout

---

```
2E, 87
2E, 87
2E, 07
2F, 08      Logical Device 8
2E, 30      Activate
2F, 01
2E, F5      Set as Second*
2F, 00
2E, F6      Set as 5
2F, 05
```

---

\* Minute: bit 3 = 0; Second: bit 3 = 1

---

## 2.5 Embedded Solid State Disk

The board supports Compact Flash Card Type II and IDE-based DiskOnChip IDE Pro and DiskOnModule (DOM) embedded flash disk. The onboard 40-pin IDE box header supports normal DOM (DiskOnModule) or M-systems DiskOnChip IDE Pro flash disk. Please note that both IDE don't provide 5V power on pin 20.

The Compact Flash Interface can support with IDE Master or Slave Mode on Jumper **JCFSEL**.

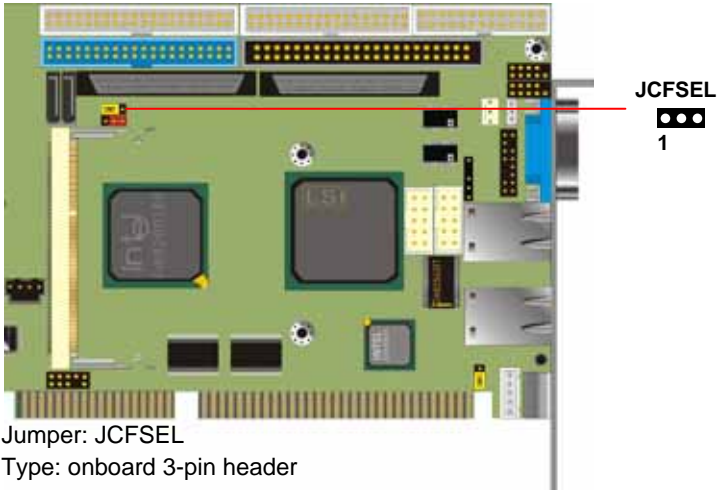

Jumper: JCFSEL

Type: onboard 3-pin header

JCFSEL	CompactFlash Address
1-2	Master
2-3	Slave
Default setting	

## 2.6 Serial ATA Setup Information

The board provide the last technology IDE connector. These two slim type connector of Serial ATA are for fast IDE data transfer. Nowadays the Serial ATA can provide the data transfer rate up to 150MB/sec. This is better than the traditional Parallel ATA (Ultra ATA/133) interface for 133MB/sec.

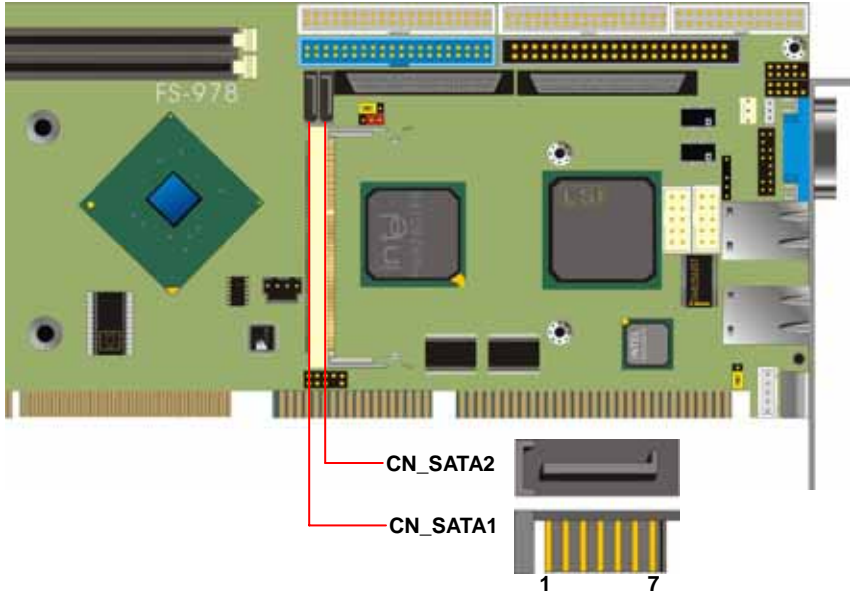

(CN_SATA 1/2) Pin Assignment						
1	2	3	4	5	6	7
GND	RSATA_TXP1	RSATA_TXN1	GND	RSATA_RXN1	RSATA_RXP1	GND

## 2.5.1 Parallel ATA and Serial ATA Device Setup

The ICH5 has defined the device usage below:

**New OS IDE mode:** ICH5 can work with up to 6 IDE Drivers under Windows 2000 or Windows XP.

**Traditional OS IDE mode:** ICH5 can only work with up to 4 IDE Drivers under MS-DOS, Windows 98 or Windows ME, and Windows NT 4.0.

Operating System	Parallel ATA		Serial ATA	
	Primary (2 Devices)	Secondary (2 Devices)	SATA1 (1 Device)	SATA2 (1 Device)
Windows 2000/XP	○	○	○	○
Windows 98/ME/NT4.0				
Type 1	○ (Primary)	<b>X</b>	○(Secondary)	○(Secondary)
Type 2	<b>X</b>	○(Secondary)	○(Primary)	○(Primary)
Type 3	○(Primary)	○(Secondary)	<b>X</b>	<b>X</b>

## 2.5.2 Parallel ATA and Serial ATA BIOS Setup

When you install the IDE drivers, please see the BIOS setup form below.

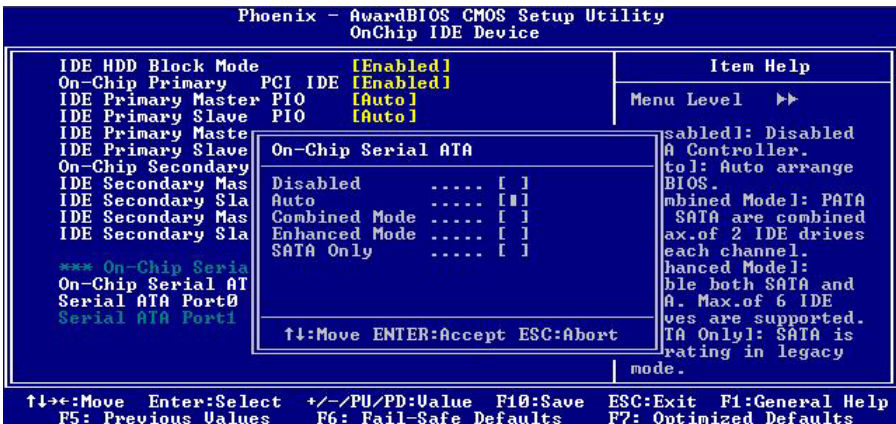

## On-Chip Serial ATA configuration:

This option allow you to setup your Serial ATA work with the modes below:

1. **Disable** : this will disable any Serial ATA Device.
2. **Auto** : this will allow you to let the BIOS auto configure your IDE drivers if you don't know how to select the mode.
3. **Combined Mode**: this will let you configure the Serial ATA and Parallel ATA enforced to max of 2 IDE devices on each Serial and Parallel ATA.
4. **Enhance Mode**: this will allow you to enable the max 6 IDE drivers. (Notice! This mode only can work under Windows 2000/XP).
5. **SATA Only Mode** : This allow you to force the Serial ATA work in legacy mode.

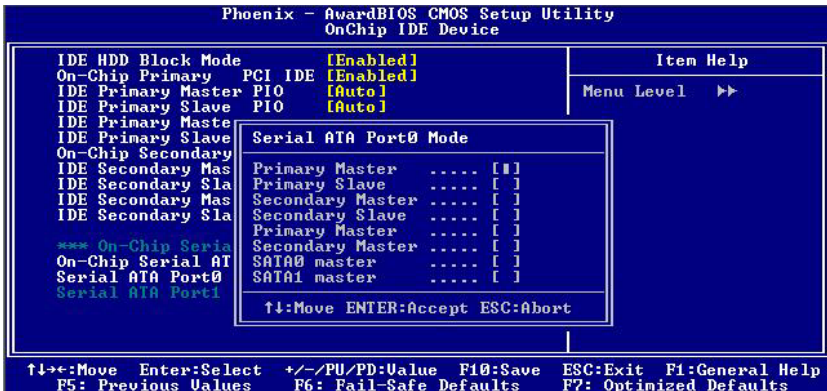

## Serial ATA Port Mode:

When you configure the Serial ATA in Combine Mode or Enhanced mode or SATA Only Mode, you can configure each driver to work as master or slave mode.

---

**Notes** (This page left blank intentionally)

A large, empty rectangular box with a thin black border, occupying most of the page. It is intended for the user to write notes, as indicated by the text above it.

---

## 2.6 Power and Fan Connector

This board provide 4-pin AT power connector, that can make you work without a backplane. Besides, this board also provide a 3-pin ATX connector.

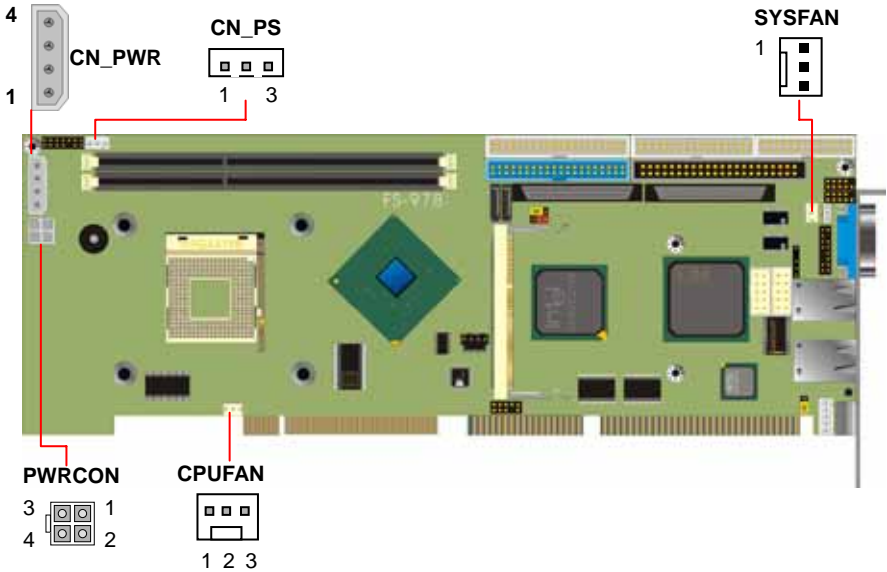

---

Connector: **CN\_PWR**

Type: 4-pin AT Power Connector

Pin	Description	Cable Color Reference
1	+12V	Yellow
2	Ground	Black
3	Ground	Black
4	+5V	RED

Connector: **PWRCON**

Type: 4-pin standard Pentium 4 additional +12V power connector

Pin	Description	Pin	Description
1	Ground	2	Ground
3	+12V	4	+12V

Connector: **CN\_PS**

Type: 3-pin ATX wafer connector

Pin	Description	Pin	Description	Pin	Description
1	5V Standby	2	Ground	3	Power On

Connector: **CPUFAN, SYSFAN**

Type: 3-pin fan wafer connector

Pin	Description	Pin	Description	Pin	Description
1	Ground	2	+12V	3	Fan Control



---

## 2.7 VGA Interface

The board is integrated with Intel 865G GMCH chipset built-in Intel Extreme Graphics 2 with 266 MHz VGA core, 256-bit 3D engine and Intel Dynamic Video Memory up to 64 MBytes shared with system memory. The CRT / analog VGA interface includes one external DB15 female connector on bracket and one internal 16-pin header on board.

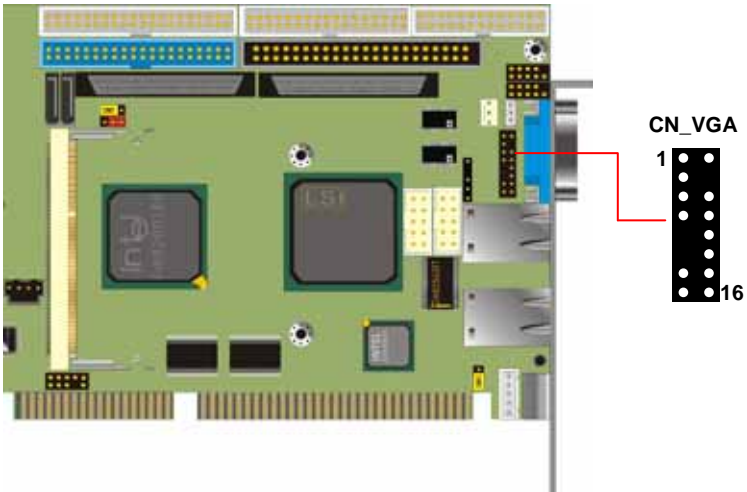

Connector: **CN\_VGA**

Type: 16-pin (2 x 8) 2.54-pitch header

Pin	Description	Pin	Description
1	Red	2	Green
3	Blue	4	N/C
5	Ground	6	Ground
7	Ground	8	Ground
9	N/C	10	Ground
11	N/C	12	Data
13	HSYNC	14	VSYNC
15	VCLK	16	N/C

---

## 2.8 Ethernet Interface

The board integrated with one Intel PRO/100+ Fast Ethernet interfaces at the type of 10Base-T/100Base-TX auto-switching Fast Ethernet and one Intel PRO/1000+ Gigabit Ethernet interface at the type of 10Base-T/100Base-TX/1000Base-T auto-switching with full duplex and IEEE 802.3U compliant. Both of them connect via RJ45 connectors on bracket. The primary LAN interface is controlled by Intel 865G with 82547GI CSA and setting as LAN1. The **OPTIONAL** secondary LAN interface is controlled by Intel ICH5 with 82562ET PHY and setting as LAN2.

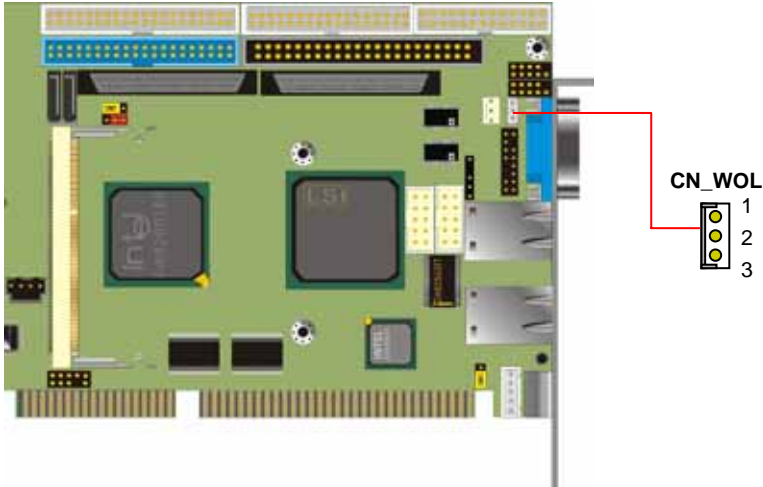

Connector: **CN\_WOL**

Type: onboard 3-pin (1 x 3) wafer connector

Pin	1	2	3
Description	WOL-Ctrl	Ground	+5V Standby

## 2.9 Audio Interface

The board integrates with AC97 3D audio interface by Intel ICH5 and Realtek ALC201A codec, provides line-in, line-out, Mic-in and CD-in interfaces for industrial applications with audio function.

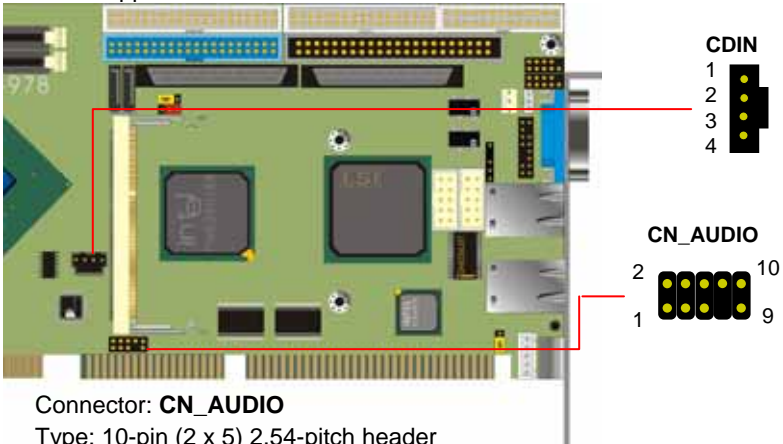

Connector: **CN\_AUDIO**

Type: 10-pin (2 x 5) 2.54-pitch header

Pin	Description	Pin	Description
1	Line – Right	2	Ground
3	Line – Left	4	MIC
5	MIC	6	Ground
7	N/C	8	Line Out – Left
9	Line Out – Right	10	Ground

Connector: **CDIN**

Type: 4-pin header

Pin	Description
1	CD – Left
2	Ground
3	Ground
4	CD – Right

## 2.10 Switch and Indicator

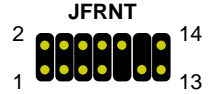
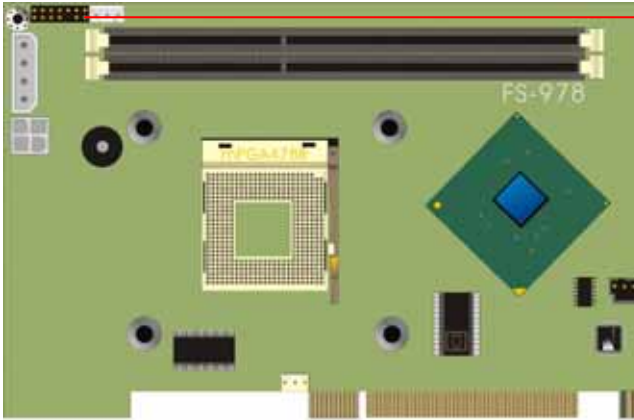

Connector: **JFRNT**

Type: onboard 14-pin (2 x 7) 2.54-pitch header

Function	Signal	PIN		Signal	Function	
<b>IDE LED</b>	Vcc (+)	1		2	(+) Vcc	<b>Power LED</b>
	Active	3		4	N/C	
<b>Reset</b>	Reset	5		6	GND	
	GND	7		8	Vcc	<b>Speaker</b>
N/C		9		10	N/C	
<b>Power Button</b>	PWRBT	11		12	N/C	
	GND	13		14	SPK	

---

## Chapter 3. BIOS Setup

The single board computer uses the Award BIOS for the system configuration. The Award BIOS in the single board computer is a customized version of the industrial standard BIOS for IBM PC AT-compatible computers. It supports Intel x86 and compatible CPU architecture based processors and computers. The BIOS provides critical low-level support for the system central processing, memory and I/O sub-systems.

The BIOS setup program of the single board computer let the customers modify the basic configuration setting. The settings are stored in a dedicated battery-backed memory, NVRAM, retains the information when the power is turned off. If the battery runs out of the power, then the settings of BIOS will come back to the default setting.

The BIOS section of the manual is subject to change without notice and is provided here for reference purpose only. The settings and configurations of the BIOS are current at the time of print, and therefore they may not be exactly the same as that displayed on your screen.

To activate CMOS Setup program, press < DEL > key immediately after you turn on the system. The following message “Press DEL to enter SETUP” should appear in the lower left hand corner of your screen. When you enter the CMOS Setup Utility, the Main Menu will be displayed as **Figure 3-1**. You can use arrow keys to select your function, press < Enter > key to accept the selection and enter the sub-menu.

**Figure 3-1.** CMOS Setup Utility Main Screen

Phoenix – Award BIOS CMOS Setup Utility

>Standard CMOS Features	>Frequency/Voltage Control
>Advanced BIOS Features	Load Fail-Safe Defaults
>Advanced Chipset Features	Load Optimized Defaults
>Integrated Peripherals	Set Supervisor Password
>Power Management Setup	Set User Password
>PnP / PCI Configurations	Save & Exit Setup
>PC Health Status	Exit Without Saving
Esc : Quit	↑ ↓ → ← : Select Item
F10 : Save & Exit Setup	

---

**Notes** (This page left blank intentionally)

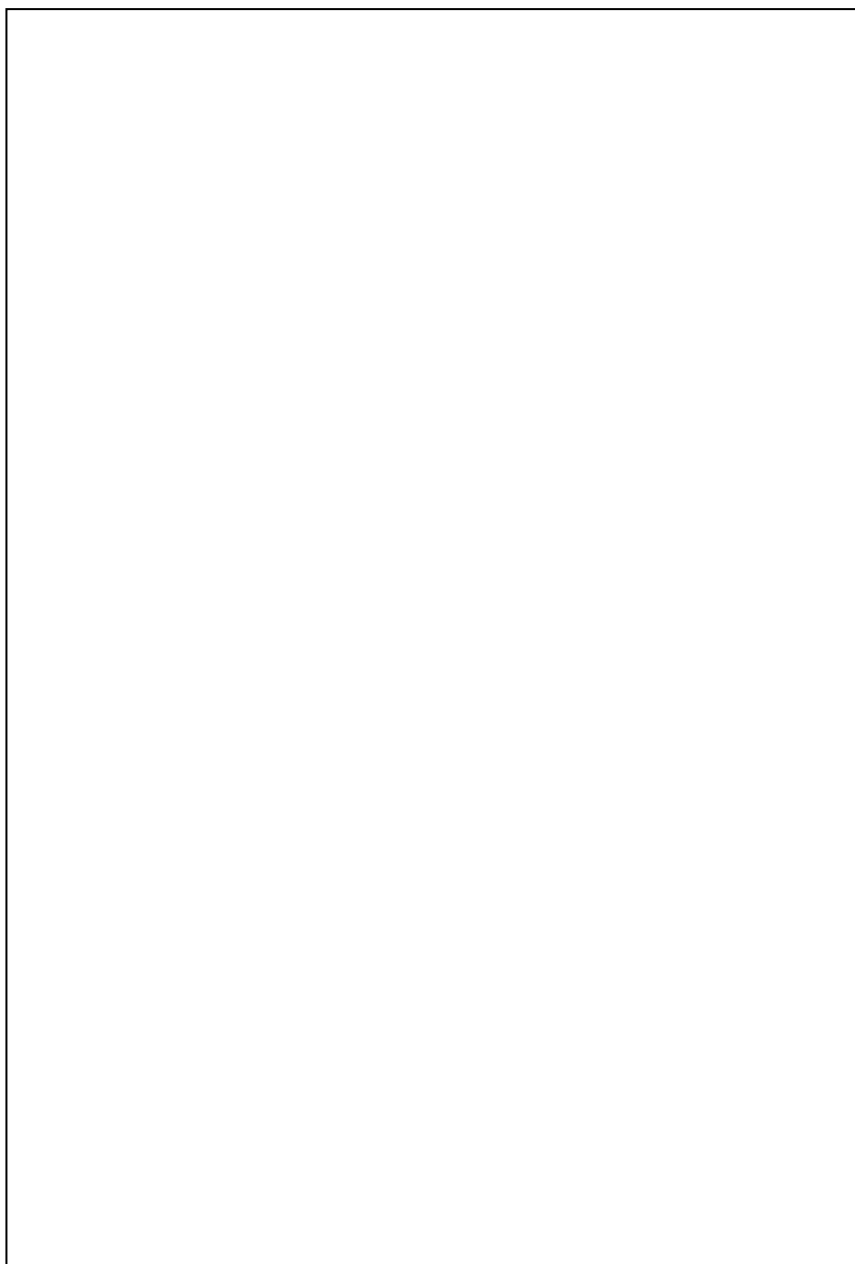
A large, empty rectangular box with a thin black border, occupying most of the page. It is intended for the user to write notes.

---

## Chapter 4. Driver Installation

The driver CD offers auto-run menu. It will detect and select the type of single board computer and helps you install the drivers automatically.

### **Install Chipset Driver**

The selection helps you to install the INF of related chipset interface.

### **Install VGA Driver**

The selection helps you to install the driver of onboard VGA interface.

### **Install LAN Driver**

The selection helps you to install the driver of onboard LAN interface.

### **Install Audio Driver**

The selection helps you to install the driver of onboard audio interface.

### **Install USB 2.0 Driver**

The selection helps you to install the driver of onboard USB 2.0 interface.

### **Link to < Website > Homepage**

The selection helps you to link to the website to find the updated technical documents and download directly.

### **Browse this CD**

The selection helps you to find the drivers in this CD directly.

---

**Notes** (This page left blank intentionally)

A large, empty rectangular box with a thin black border, occupying most of the page. It is intended for the user to write notes.



---

# Appendix. A I/O Port Pin Assignment

## A.1 IDE Port

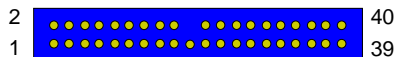

Connector: **IDE1, IDE2**

Type: 40-pin (2 x 20) 2.54-pitch box header

Pin	Description	Pin	Description
1	Reset	2	Ground
3	D7	4	D8
5	D6	6	D9
7	D5	8	D10
9	D4	10	D11
11	D3	12	D12
13	D2	14	D13
15	D1	16	D14
17	D0	18	D15
19	Ground	20	N/C
21	REQ	22	Ground
23	IOW-/STOP	24	Ground
25	IOR-/HDMARDY	26	Ground
27	IORDY/DDMARDY	28	IDESEL
29	DACK-	30	Ground
31	IRQ	32	N/C
33	A1	34	CBLID
35	A0	36	A2
37	CS0 (MASTER CS)	38	CS1 (SLAVE CS)
39	LED ACT-	40	Ground

## A.2 Floppy Port

Connector: **FDD**

Type: 34-pin (2 x 17) 2.54-pitch header

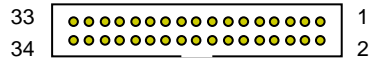

Pin	Description	Pin	Description
1	Ground	2	DRIVE DENSITY SELECT 0
3	Ground	4	DRIVE DENSITY SELECT 1
5	Ground	6	N/C
7	Ground	8	INDEX-
9	Ground	10	MOTOR ENABLE A-
11	Ground	12	DRIVER SELECT B-
13	Ground	14	DRIVER SELECT A-
15	Ground	16	MOTOR ENABLE B-
17	Ground	18	DIRECTION-
19	Ground	20	STEP-
21	Ground	22	WRITE DATA-
23	Ground	24	WRITE GATE-
25	Ground	26	TRACK 0-
27	Ground	28	WRITE PROTECT-
29	Ground	30	READ DATA-
31	Ground	32	HEAD SELECT-
33	Ground	34	DISK CHANGE-

---

## A.3 Parallel Port

Connector: **LPT**

Type: 26-pin (2 x 13) 2.54-pitch box header

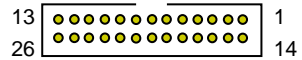

Pin	Description	Pin	Description
1	STROBE-	14	AUTO FEED-
2	D0	15	ERROR-
3	D1	16	INITIALIZE-
4	D2	17	SELECT INPUT-
5	D3	18	Ground
6	D4	19	Ground
7	D5	20	Ground
8	D6	21	Ground
9	D7	22	Ground
10	ACKNOWLEDGE-	23	Ground
11	BUSY	24	Ground
12	PAPER EMPTY	25	Ground
13	SELECT+	26	N/C

---

## A.4 Serial Port

### A.4.1 Onboard RS-232C Serial Port

Connector: **JCOM1, JCOM2**

Type: 10-pin (2 x 5) 2.54-pitch header

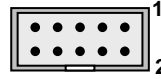

Pin	Description	Pin	Description
1	DCD	2	RXD
3	TXD	4	DTR
5	Ground	6	DSR
7	RTS	8	CTS
9	RI	10	N/C

### A.4.2 On Bracket RS-232C Serial Port

Connector: **COM1** (Optional for FS-978VL only)

Type: 9-pin D-sub male connector on bracket

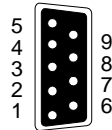

Pin	Description	Pin	Description
1	DCD	2	RXD
3	TXD	4	DTR
5	Ground	6	DSR
7	RTS	8	CTS
9	RI		

---

## A.5 USB Port

Connector: **CN\_USB1, CN\_USB2**

Type: 10-pin (2 x 5) header for dual USB Ports



Pin	Description	Pin	Description
1	Vcc	6	Vcc
2	Data0-	7	Data1-
3	Data0+	8	Data1+
4	Ground	9	Ground
5	Ground	10	N/C

## A.6 IrDA Port

Connector: **CN\_IR**

Type: 5-pin (1 x 5) 2.54-pitch header for SIR Port



Pin	Description
1	Vcc
2	N/C
3	IRRXD
4	Ground
5	IRTXD

## A.7 VGA Port

Connector: **VGA**

Type: 15-pin D-sub female connector on bracket

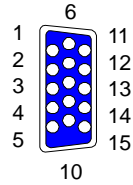

Pin	Description	Pin	Description	Pin	Description
1	RED	6	Ground	11	N/C
2	GREEN	7	Ground	12	5VCCA
3	BLUE	8	Ground	13	HSYNC
4	N/C	9	LVGA5V	14	VSYNC
5	Ground	10	Ground	15	5VCLK

## A.8 LAN Port

Connector: **LAN1**

Type: RJ45 connector with LED on bracket

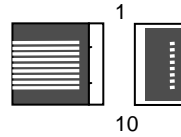

Pin	1	2	3	4	5
Description	TRD0+	TRD0-	TRD1+	TRD1-	NC
Pin	6	7	8	9	10
Description	NC	TRD2+	TRD2-	TRD3+	TRD3-

Connector: **LAN2** (Optional for **FS-978VL2**)

Type: RJ45 connector with LED on bracket

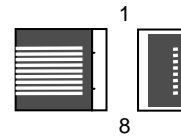

Pin	1	2	3	4	5	6	7	8
Description	TX+	TX-	RX+	N/C	N/C	RX-	N/C	N/C

---

## A.9 AT Keyboard Port

Connector: **CN\_ATKB**  
Type: 5-pin box header

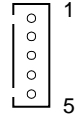

Pin	1	2	3	4	5
Description	CLK	DATA	N/C	Ground	Vcc

## A.10 PS/2 Keyboard and Mouse Port

Connector: **PS2**  
Type: 6-pin MiniDIN connector on bracket

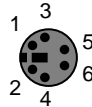

Pin	1	2	3	4	5	6
Description	KBD	MSD	Ground	N/C	KBC	MSC

Note: The PS/2 connector supports standard PS/2 keyboard directly or both PS/2 keyboard and mouse through the PS/2 Y-type cable. The cable is the standard on packing list.

---

**Notes** (This page left blank intentionally)

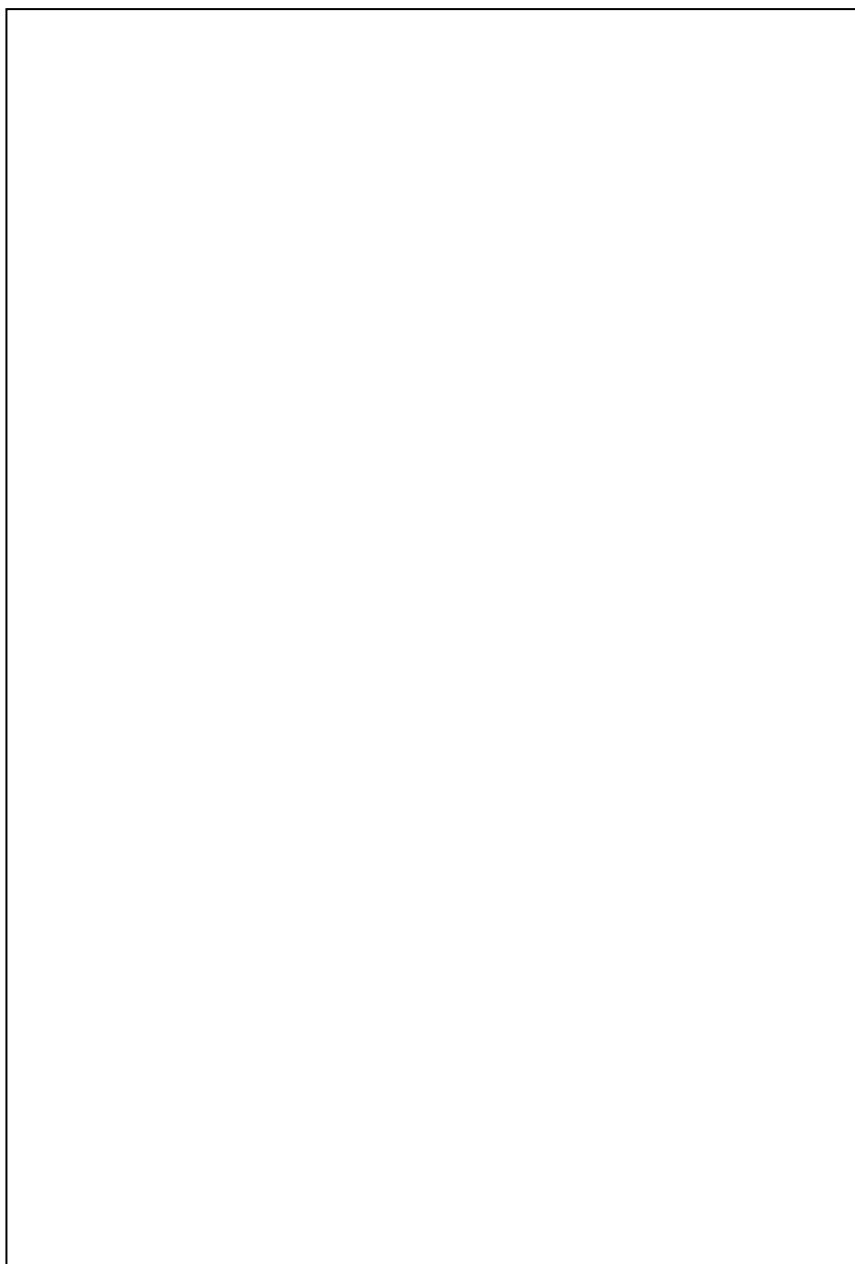
A large, empty rectangular box with a thin black border, occupying most of the page. It is intended for the user to write notes, as indicated by the text above it.



---

## Appendix B. Flash the BIOS

### B.1 BIOS Auto Flash Tool

The board is based on Award BIOS and can be updated easily by the BIOS auto flash tool. You can download the tool online at the address below:

<http://www.award.com>

[http://www.commell.com.tw/Support/Support\\_SBC.htm](http://www.commell.com.tw/Support/Support_SBC.htm)

File name of the tool is "awdfash.exe", it's the utility that can write the data into the BIOS flash chip and update the BIOS.

### B.2 Flash Method

1. Get the ".bin" file including the image of new BIOS you want to update.
2. Power on the system and flash the BIOS.
3. Re-start the system.

Any question about the BIOS re-flash please contact your distributors or visit our website at below:

[http://www.commell.com.tw/Support/Support\\_SBC.htm](http://www.commell.com.tw/Support/Support_SBC.htm)

---

**Notes** (This page left blank intentionally)

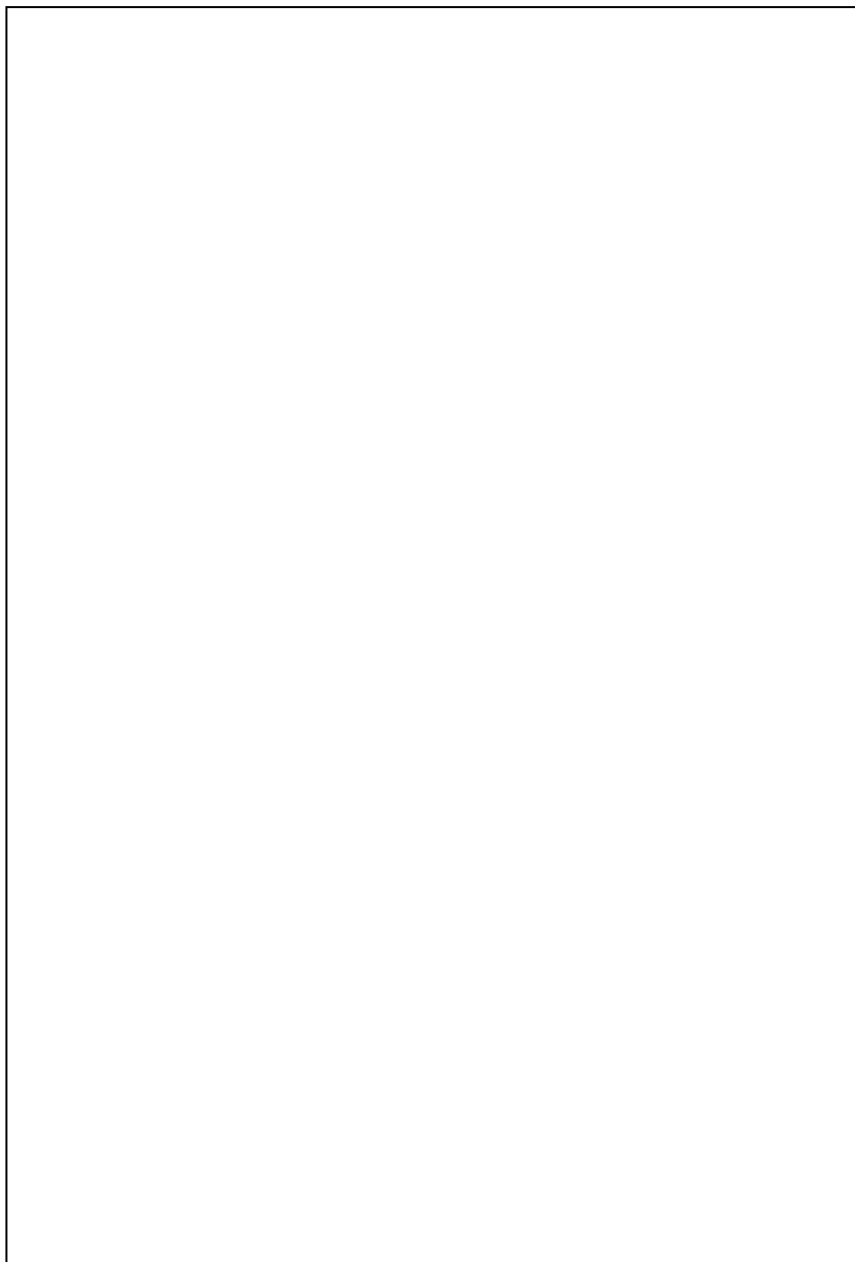
A large, empty rectangular box with a thin black border, occupying most of the page. It is intended for the user to write notes.

---

# Appendix C. System Resource

## C.1 I/O Port Address Map

<b>Address Range</b>	<b>Device</b>
x0000 - x000F	Direct Access Memory Controller
x0010 - x001F	Motherboard Resource
x0020 - x0021	Programmable Interrupt Controller
x0022 - x003F	Motherboard resource
x0040 - x0043	System Clock
x0044 - x005F	Motherboard Resource
x0060 - x0060	Standard 101/102-Key or Microsoft Natural Keyboard
x0061 - x0061	System Speaker
x0062 - x0063	Motherboard Resource
x0064 - x0064	Standard 101/102-Key or Microsoft Natural Keyboard
x0065 - x006F	Motherboard Resource
x0070 - x0073	System CMOS/ Real Time Clock
x0074 - x007F	Motherboard Resource
x0080 - x0090	Direct Access Memory controller
x0091 - x0093	Motherboard Resource
x0094 - x009F	Direct Access Memory Controller
x00A0 - x00A1	Programmable Interrupt Controller
x00A2 - x00BF	Motherboard Resource
x00C0 - x00DF	Direct Access Memory Controller
x00E0 - x00EF	Motherboard Resource
x00F0 - x00FF	Numeric Data Processor
x0170 - x0177	Intel(R) 82801EB Ultra ATA Storage Controllers
x0170 - x0177	Secondary IDE controller (dual fifo)
x01F0 - x01F7	Intel(R) 82801EB Ultra ATA Storage Controllers
x01F0 - x01F7	Primary IDE controller (dual fifo)
x02F8 - x02FF	Communication Port (COM2)
x0376 - x0376	Intel(R) 82801EB Ultra ATA Storage Controllers
x0376 - x0376	Secondary IDE controller (dual fifo)
x0378 - x037F	Printer Port (LPT1)
x03B0 - x03BB	Intel(R) 82865G Graphics Controller
x03C0 - x03DF	Intel(R) 82865G Graphics Controller
x03F0 - x03F5	Standard Floppy Controller
x03F6 - x03F6	Intel(R) 82801EB Ultra ATA Storage Controllers
x03F6 - x03F6	Primary IDE controller (dual fifo)
x03F7 - x03F7	Standard Floppy Controller
x03F8 - x03FF	Communication Port (COM1)

---

x0400 - x04BF	Motherboard Resource
x04D0 - x04D1	Motherboard Resource
x0500 - x051F	Intel(R) 82801EB SMBus Controller - 24D3
x0778 - x077B	Printer Port (LPT1)
x0A78 - x0A7B	Motherboard Resource
x0B78 - x0B7B	Motherboard Resource
x0BBC - x0BBF	Motherboard Resource
x0CF8 - x0CFF	PCI Bus
x0E78 - x0E7B	Motherboard Resource
x0F78 - x0F7B	Motherboard Resource
x0FBC - x0FBF	Motherboard Resource
xA000 - xA01F	Intel(R) PRO/1000 CT Desktop Connection
xA000 - xAFFF	Intel(R) 82865G\PE\PI PCI to CSA bridge - 2573
xB000 - xB03F	Intel(R) PRO/100 VE Network Connection
xB000 - xBFFF	Intel(R) 82801EB PCI Bridge - 244E
xC400 - xC41F	Intel(R) 82801EB USB Universal Host Controller - 24D4
xC800 - xC81F	Intel(R) 82801EB USB Universal Host Controller - 24D7
xCC00 - xCC1F	Intel(R) 82801EB USB Universal Host Controller - 24DE
xD000 - xD007	Intel(R) 82865G Graphics Controller
xD800 - xD8FF	Realtek AC'97 Audio
xDC00 - xDC3F	Realtek AC'97 Audio
xF000 - xF007	Primary IDE controller (dual fifo)
xF000 - xF00F	Intel(R) 82801EB Ultra ATA Storage Controllers
xF008 - xF00F	Secondary IDE controller (dual fifo)

---

---

## C.2 Memory Address Map

<b>Address Range</b>	<b>Device</b>
x00000000 - x0009FFFF	System board extension for ACPI BIOS
x000A0000 - x000AFFFF	Intel(R) 82865G Graphics Controller
x000B0000 - x000BFFFF	Intel(R) 82865G Graphics Controller
x000C0000 - x000CA3FF	Intel(R) 82865G Graphics Controller
x000CC000 - x000CFFFF	System board extension for ACPI BIOS
x000E0000 - x000EFFFF	System board extension for ACPI BIOS
x000F0000 - x000F7FFF	System board extension for ACPI BIOS
x000F8000 - x000FBFFF	System board extension for ACPI BIOS
x000FC000 - x000FFFFF	System board extension for ACPI BIOS
x00100000 - x1EFFFFFFF	System board extension for ACPI BIOS
x1EFF0000 - x1EFFFFFFF	System board extension for ACPI BIOS
xE8000000 - xEFFFFFFF	Intel(R) 82865G\PE\VP Processor to I/O Controller - 2570
xF0000000 - xF7FFFFFFF	Intel(R) 82865G Graphics Controller
xF8000000 - xF801FFFF	Intel(R) PRO/1000 CT Desktop Connection
xF8000000 - xF80FFFFFFF	Intel(R) 82865G\PE\VP PCI to CSA bridge - 2573
xF8100000 - xF8100FFF	Intel(R) PRO/100 VE Network Connection
xF8100000 - xF81FFFFFFF	Intel(R) 82801EB PCI Bridge - 244E
xF8200000 - xF827FFFF	Intel(R) 82865G Graphics Controller
xF8280000 - xF82803FF	Intel USB 2.0 Enhanced Host Controller
xF8281000 - xF82811FF	Realtek AC'97 Audio
xF8282000 - xF82820FF	Realtek AC'97 Audio
xFEC00000 - xFEC00FFF	System board extension for ACPI BIOS
xFEC01000 - xFED8FFFFF	System board extension for ACPI BIOS
xFEE00000 - xFEE00FFF	System board extension for ACPI BIOS
xFFB00000 - xFFB7FFFF	System board extension for ACPI BIOS
xFFB80000 - xFFBFFFFFFF	Intel(r) 82802 Firmware Hub Device
xFFFF0000 - xFFFFFFF	System board extension for ACPI BIOS

---

## C.3 IRQ and DMA Resource

### C.3.1 IRQ

<b>IRQ Number</b>	<b>Device</b>
0	System Clock
1	Standard 101/102-Key or Microsoft Natural Keyboard
2	Programmable Interrupt Controller
3	Communication Port (COM2)
4	Communication Port (COM1)
5	Intel(R) 82801EB USB Universal Host Controller - 24DE
5	Intel(R) 82801EB USB Universal Host Controller - 24D2
5	Intel(R) 82865G Graphics Controller
5	ACPI IRQ Holder for PCI IRQ Steering
6	Standard Floppy Controller
7	Printer Port (LPT1)
8	System CMOS/ Real Time Clock
9	Realtek AC'97 Audio
9	Intel(R) 82801EB SMBus Controller - 24D3
9	ACPI IRQ Holder for PCI IRQ Steering
9	SCI IRQ used by ACPI bus
10	Intel(R) PRO/100 VE Network Connection
10	Intel(R) 82801EB USB Universal Host Controller - 24D7
10	ACPI IRQ Holder for PCI IRQ Steering
10	ACPI IRQ Holder for PCI IRQ Steering
11	Intel USB 2.0 Enhanced Host Controller
11	Intel(R) 82801EB USB Universal Host Controller - 24D4
11	Intel(R) PRO/1000 CT Desktop Connection
11	ACPI IRQ Holder for PCI IRQ Steering
11	ACPI IRQ Holder for PCI IRQ Steering
12	PS/2 Compatible Mouse Port
13	Numeric Data Processor
14	Primary IDE controller (dual fifo)
14	Intel(R) 82801EB Ultra ATA Storage Controllers
15	Secondary IDE controller (dual fifo)
15	Intel(R) 82801EB Ultra ATA Storage Controllers

---

## C.3.2 DMA

<b>Channel</b>	<b>Device</b>
0	(free)
1	(free)
2	Standard Floppy Disk Controller
3	(free)
4	Direct Memory Access Controller
5	(free)
6	(free)
7	(free)

---

---

## Contact Information

Any advice or comment about our products and service, or anything we can help you please don't hesitate to contact with us. We will do our best to support you for your products, projects and business.

**COMMELL Industrial Computer  
Taiwan Commate Computer Inc.**

**COMMELL**

[www.commell.com.tw](http://www.commell.com.tw)

Your Embedded Applied Computer Partner

---

Address	8F, No. 94, Sec. 1, Shin Tai Wu Rd., Shi Chih Taipei Hsien, Taiwan
TEL	+886-2-26963909
FAX	+886-2-26963911
Website	<a href="http://www.commell.com.tw">http://www.commell.com.tw</a>
E-mail	<a href="mailto:info@commell.com.tw">info@commell.com.tw</a> (General Information) <a href="mailto:tech@commell.com.tw">tech@commell.com.tw</a> (Technical Support)

---

### Authorized Distributor